



High Efficiency

PAL Series 3-Phase

0.75kW

■ SPECIFICATION

■ MOTOR

Output (kW)	Model Name	Poles	Voltage (V)	Freq. (Hz)	Rated Load			Duty	Degrees of protection	Insulation Classification	Protective Cooling System
					Current (A)	Speed (r/min)	Efficiency (%)				
0.75	PAL□-□-E□075R4□	4	220/380	60	3,10/1,80	1705	82,8	CONT.	IP55	F	Totally Enclosed Fan-Cooled
	PAL□-□-E□075W6□	4	200	50	3,45	1415	79,6				
			220	60	3,10	1710	83,5				
	PAL□-□-E□075X6□	4	380/400	50	1,80/1,80	1420/1425	79,6/79,6				
			400/440	60	1,65/1,60	1700/1720	82,5/82,9				

- The Brake Geared Motor is divided into 2 models: one is a non-water proof product with IP40 while the other is a waterproof product with IP55.
- The Models with IP40 and IP55 have the same electric characteristics.

■ GEARED MOTOR – 50Hz

Frame No.	28					32						40				
Reduction gear ratio	5	10	15	20	25	30	40	50	60	80	★100	100	120	160	★200	
Rotation speed (r/min)	300	150	100	75	60	50	37,5	30	25	18,8	15	15	12,5	9,4	7,5	
Allowable torque	kgf · m	2,3	4,6	6,9	9,3	11,6	13,9	17,9	22,4	26,9	35,8	36,9	44,8	53,8	71,7	78
	N · m	23	45	68	91	114	136	175	220	264	351	362	439	527	703	764
Allowable O.H.L	kgf	130	180	220	240	250	410	430	470	560	600	600	720	720	720	720
	N	1270	1760	2160	2350	2450	4020	4210	4610	5490	5880	5880	7060	7060	7060	7060

■ GEARED MOTOR – 60Hz

Frame No.	28					32						40				
Reduction gear ratio	5	10	15	20	25	30	40	50	60	80	★100	100	120	160	200	
Rotation speed (r/min)	360	180	120	90	72	60	45	36	30	22,5	18	18	15	11,2	9	
Allowable torque	kgf · m	1,9	3,9	5,8	7,7	9,6	11,6	14,9	18,7	22,4	29,9	30,8	37,3	44,8	59,7	74,7
	N · m	19	38	57	75	94	114	146	183	220	293	302	366	439	585	732
Allowable O.H.L	kgf	130	180	220	240	250	410	430	470	560	600	600	720	720	720	720
	N	1270	1760	2160	2350	2450	4020	4210	4610	5490	5880	5880	7060	7060	7060	7060

- Note) • Permissible O.H.L (allowable overhung load) is based on the central part of the outlet length for output shaft
 • Permissible Torque is limited for products with a mark "★" of reduction gear ratio
 • ■ Color indicates the same direction of motor rotation, while other color indicates the opposite direction of motor rotation.

Model Name Coding
36PageSpecification for output shaft
70PageTechnological Data
101Page

■ PAL TYPE DIMENSIONS [Lead wire Box Type]

UNIT = mm

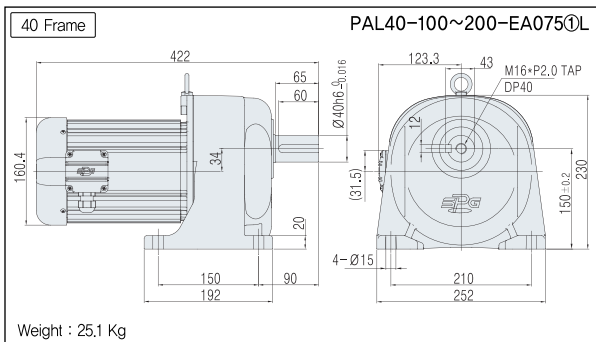
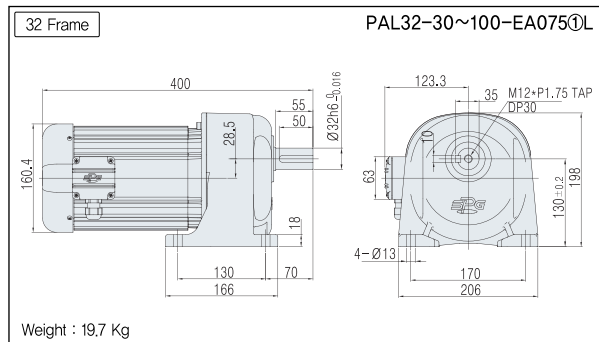
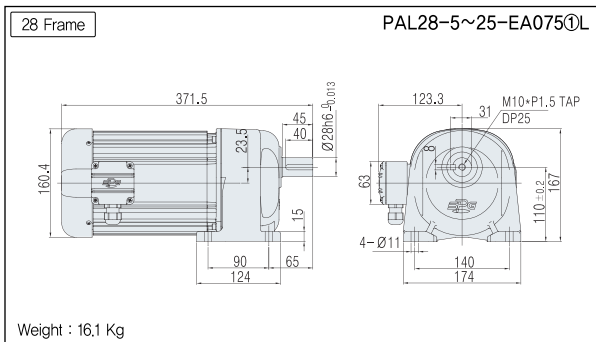

- Model type ① : Power (Voltage & Frequency)
- Lead wire Box for 0.2~0.75kW

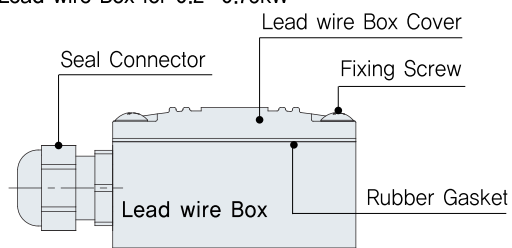

■ PAL TYPE DIMENSIONS [Terminal Box Type]

- Note)
- Dimensions for IP40 model and IP55 model are the same.
 - The brake-attached model is applied to the Terminal Box Type for basic features, but does not apply to the lead wire box type.
 - () dimension and weight in dimensions is for brake attached model specification

UNIT = mm

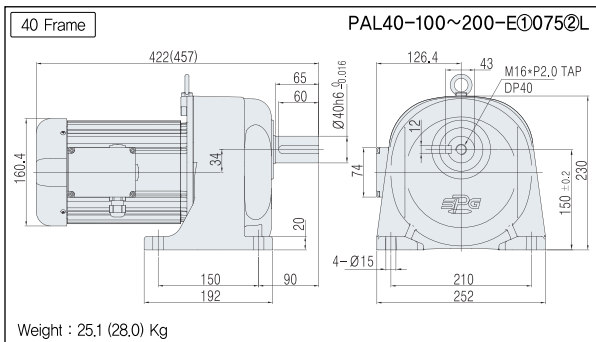
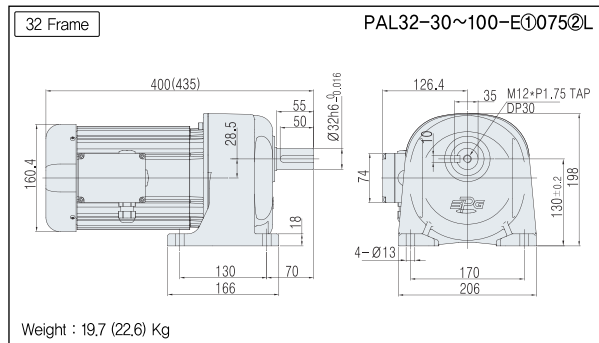
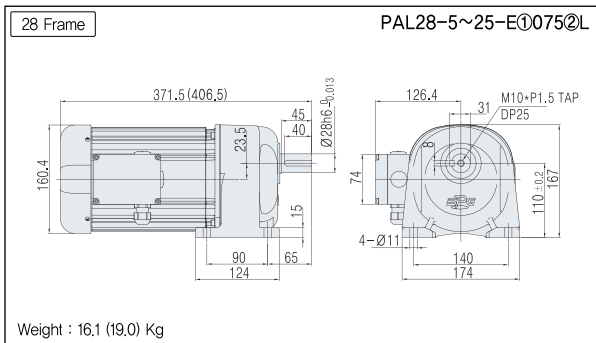

- Model type ① : Motor option (B, C, D)
- ② : Power (Voltage & Frequency)
- Terminal Box for 0.2~0.75kW

